

---

**ISTRUZIONI PER L'INSTALLAZIONE E LA MANUTENZIONE**  
**INSTRUCTIONS POUR L'INSTALLATION ET LA MAINTENANCE**  
**INSTRUCTIONS FOR INSTALLATION AND MAINTENANCE**  
**INSTALLATIONS-UND WARTUNGSANLEITUNGEN**  
**INSTRUCTIES VOOR INSTALLATIE EN ONDERHOUD**  
**INSTRUCCIONES PARA LA INSTALACIÓN Y MANTENIMIENTO**  
**INSTALLATIONS-OCH UNDERHÅLLSANVISNINGAR**  
**ΟΔΗΓΙΕΣ ΓΙΑ ΤΗΝ ΕΓΚΑΤΑΣΤΑΣΗ ΚΑΙ ΤΗ ΣΥΝΤΗΡΗΣΗ**  
**KURMA VE BAKIM İÇİN BİLGİLER**  
**NÁVOD NA INŠTALÁCIU A ÚDRŽBU**  
**РУКОВОДСТВО ПО МОНТАЖУ И ТЕХНИЧЕСКОМУ ОБСЛУЖИВАНИЮ**  
**INSTRUCȚIUNI PENTRU INSTALARE ȘI ÎNTREȚINERE**  
إرشادات خاصة بالتركيب والرعاية

**ACTIVE DRIVER M/M 1.1**

**ACTIVE DRIVER M/T 1.0**

**ACTIVE DRIVER M/T 2.2**

**ACTIVE DRIVER T/T 3.0**

**ACTIVE DRIVER T/T 5.5**



---

**ACTIVE DRIVER M/M 1.1**  
**ACTIVE DRIVER M/T 1.0 - ACTIVE DRIVER M/T 2.2**  
**ACTIVE DRIVER T/T 3.0 - ACTIVE DRIVER T/T 5.5**

**DICHIARAZIONE DI CONFORMITÀ**

La Ditta DAB PUMPS s.p.a. - Via M. Polo,14 - Mestrino (PD) - ITALIA - sotto la propria esclusiva responsabilità dichiara che i prodotti summenzionati sono conformi a:

- Direttiva della Compatibilità elettromagnetica 89/336 e successive modifiche.
- Direttiva Bassa Tensione 73/23 e successive modifiche.

**DÉCLARATION DE CONFORMITÉ**

La société DAB PUMPS s.p.a. – Via M. Polo, 14 – Mestrino (PD) – ITALY – sous sa propre responsabilité exclusive déclare que les produits susmentionnés sont conformes à:

- Directive de la Compatibilité électromagnétique 89/336 et modifications successives.
- Directive Basse Tension 73/23 et modifications successives.

**DECLARATION OF CONFORMITY**

The Company DAB PUMPS s.p.a. – Via M. Polo, 14 – Mestrino (PD) – ITALY – under its own exclusive responsibility declares that the products listed above comply with:

- Directive on Electromagnetic Compatibility 89/336 and subsequent modifications.
- Directive on Low Voltage 73/23 and subsequent modifications.

**KONFORMITÄTSERKLÄRUNG**

Die Firma DAB PUMPS s.p.a. – Via M. Polo, 14 – Mestrino (PD) – ITALIEN – erklärt eigenverantwortlich, dass die vorstehend beschriebenen Produkte den folgenden Richtlinien entsprechen:

- Richtlinie zur elektromagnetischen Verträglichkeit 89/336 und folgende Änderungen.
- Niederspannungsrichtlinie 73/23 und folgende Änderungen.

**CONFORMITEITSVERKLARING**

De firma DAB PUMPS s.p.a. – Via M. Polo, 14 – Mestrino (PD) – ITALY – verklaart onder haar eigen, exclusieve verantwoording dat de hieronder genoemde producten voldoen aan:

- Richtlijn elektromagnetische compatibiliteit 89/336 en successievelijke wijzigingen.
- Laagspanningsrichtlijn 73/23 en successievelijke wijzigingen.

**DECLARACIÓN DE CONFORMIDAD**

La empresa DAB PUMPS s.p.a. – Via M. Polo, 14 – Mestrino (PD) – ITALIA – declara bajo su total responsabilidad que los productos anteriormente mencionados cumplen la:

- Directiva de Compatibilidad Electromagnética 89/336 y sucesivas modificaciones.
- Directiva de Baja Tensión 73/23 y sucesivas modificaciones.

**FÖRSÄKRAN OM CE-ÖVERENSSTÄMMELSE**

Företaget DAB PUMPS s.p.a. – Via M. Polo 14, Mestrino (PD) – ITALIEN – förklarar på eget ansvar att ovannämnda produkter är i överensstämmelse med:

- EMC-direktivet 89/336/EEG jämte ändringar.
  - Lågspänningsdirektivet 73/23/EEG jämte ändringar.
-

---

**ACTIVE DRIVER M/M 1.1**  
**ACTIVE DRIVER M/T 1.0 - ACTIVE DRIVER M/T 2.2**  
**ACTIVE DRIVER T/T 3.0 - ACTIVE DRIVER T/T 5.5**

**ΔΗΛΩΣΗ ΣΥΜΜΟΡΦΩΣΗΣ**

Η εταιρεία DAB PUMPS s.p.a. – Via M. Polo, 14 – Mestrino (PD) – ITALY – δηλώνει υπεύθυνα πως τα προϊόντα που αναφέρονται παραπάνω, εναρμονίζονται με:

- Την οδηγία περί μαγνητικής συμβατότητας 89/336/ΕΟΚ και μετέπειτα τροποποιήσεις.
- Την οδηγία περί χαμηλής τάσης 73/23/ΕΟΚ και μετέπειτα τροποποιήσεις.

**UYGUNLUK BEYANNAMESİ**

- Via M. Polo, 14 – Mestrino (PD) – ITALY – adresinde yerleşik DAB PUMPS s.p.a. Şirketi, sadece kendi sorumluluğu altında sözü geçen ürünlerin aşağıdaki yönetmeliklere uygun olduğunu beyan etmektedir:

- 89/336 sayılı elektromanyetik Uygunluk Yönergesi ve daha sonraki değişiklikler.
- 73/23 sayılı Alçak Gerilim Yönergesi ve daha sonraki değişiklikler.

**VYHLÁSENIE O ZHODE**

Spoločnosť DAB PUMPS s.p.a. – Via M. Polo, 14 – Mestrino (PD) – Taliansko, vyhlasuje na vlastnú výhradnú zodpovednosť, že výrobky uvedené v d'alsom texte zodpovedajú.

- Smernici Elektromagnetická kompatibilita č. 89/336 a nasledujúcim úpravám.
- Smernici Nízke napätie č. 73/23 a nasledujúcim úpravám.

**ЗАЯВЛЕНИЕ О СООТВЕТСТВИИ**

Фирма DAB PUMPS s.p.a. – Вия М. Поло, 14 – Местрино (ПД) – ИТАЛИЯ – под собственную исключительную ответственность заявляет, что вышеуказанные изделия соответствуют:

- Директиве по Электромагнитной совместимости 89/336 и последующим изменениям.
- Директиве по Низкому напряжению 73/23 и последующим изменениям.

**DECLARAȚIE DE CONFORMITATE**

Întreprinderea DAB PUMPS s.p.a. – Via M. Polo, 14 – Mestrino (PD) – ITALIA – pe exclusivă proprie răspundere declară că produsele mai sus menționate sunt conforme cu:

- Directiva Compatibilității electromagnetice 89/336 și următoarele modificări.
- Directiva de Joasă Tensiune 73/23 și următoarele modificări.

**شهادة مطابقة**

- مسؤوليتها الخاصة تصرّح بأن المنتجات المذكورة أعلاه مطابقة إلى:
- قانون المطابقة المغنطيسية الكهربائية رقم 336/89 والتعديلات اللاحقة به.
  - قانون الجهد المنخفض رقم 23/73 والتعديلات اللاحقة به.

Mestrino (PD), 31/03/2004

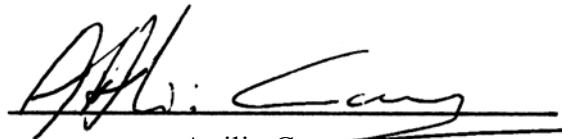

Attilio Conca  
Legale Rappresentante  
Legal Representative

---

	page
<b>INDEX</b>	
1. <b>GENERAL</b>	25
2. <b>WARNINGS</b>	25
3. <b>APPLICATIONS</b>	26
4. <b>TECHNICAL DATA AND LIMITATIONS OF USE</b>	26
5. <b>ELECTRICAL CONNECTIONS OF THE ACTIVE DRIVER TO THE ELECTROPUMP</b>	26
6. <b>CONNECTION TO THE POWER SUPPLY LINE</b>	26
7. <b>HYDRAULIC CONNECTIONS</b>	27
8. <b>CHARACTERISTICS – INTERPRETATIONS – OPERATION</b>	27
8.1 <b>Characteristics and interpretations</b>	27
8.2 <b>Operation: keyboard setting</b>	28
8.3 <b>Operation: parameters for the user</b>	29
8.4 <b>Operation: parameters for the installer</b>	29
8.5 <b>Operation: technical assistance displays and settings</b>	31
9. <b>DISPLAYS</b>	33
9.1 <b>Displays of the main values</b>	33
9.2 <b>Monitor displays</b>	33
10. <b>ACCESS TO MANUAL MODE OF THE MACHINE</b>	33
11. <b>GENERAL SYSTEM RESET</b>	34
12. <b>RESTORING THE FACTORY SETTINGS</b>	34
13. <b>ERROR AND STATUS CONDITIONS</b>	34
14. <b>TABLE OF INDICATIONS ON THE DISPLAY</b>	36

## 1. GENERAL



**Read this documentation carefully before installation.** Installation and functioning must comply with the safety regulations in force in the country in which the product is installed. The entire operation must be carried out in a workmanlike manner.

Failure to comply with the safety regulations not only causes risk to personal safety and damage to the equipment, but invalidates every right to assistance under guarantee.

## 2. WARNINGS

### 2.1 Skilled personnel



**It is advisable that installation be carried out by competent, skilled personnel in possession of the technical qualifications required by the specific legislation in force.**

The term **skilled personnel** means persons whose training, experience and instruction, as well as their knowledge of the respective standards and requirements for accident prevention and working conditions, have been approved by the person in charge of plant safety, authorizing them to perform all the necessary activities, during which they are able to recognize and avoid all dangers. (Definition for technical personnel IEC 364).

### 2.2 Safety

Use is allowed only if the electric system is in possession of safety precautions in accordance with the regulations in force in the country where the product is installed (for Italy, IEC 64/2).

### 2.3 Responsibility



**The Manufacturer does not vouch for correct operation of the ACTIVE DRIVER or for any damage that it may cause if it has been tampered with, modified and/or run outside the recommended work range or in contrast with other indications given in this manual. The Manufacturer declines all responsibility for possible errors in this instructions manual, if due to misprints or errors in copying. The Manufacturer reserves the right to make any modifications to products that it may consider necessary or useful, without affecting the essential characteristics.**

### 2.4 PARTICULAR WARNINGS



**Before working on the electrical or mechanical part of the system, always turn off the mains voltage. Wait at least five minutes after the power supply to the machine has been switched off before opening the appliance.** The condenser of the continuous intermediate circuit remains charged with dangerously high voltage even after the mains voltage has been switched off.

Only firmly wired mains connections are admissible. The appliance must be earthed (IEC 536 class 1, NEC and other relevant standards).

**Mains terminals may carry dangerous voltage even when the motor is stopped.**

In determined calibration conditions, after a power cut the converter may start automatically.

Pay attention: the **motor terminals U, V and W (for the Active Driver M/M 1.1 the motor terminals R and S)**, may carry dangerous voltages even when the converter is not operating.

Do not operate the appliance in direct sunlight.

This appliance may not be used as an “EMERGENCY STOP mechanism” (see EN 60204, 9.2.5.4).

### 3. APPLICATIONS

The Active Driver M/T is fed with a single-phase line and it drives electropumps with a standard three-phase 230V asynchronous motor.

The Active Driver M/M is fed with a single-phase line and it drives electropumps with a standard single-phase 230V asynchronous motor.

The Active Driver T/T is fed with a line three-phase and it drives electropumps with a standard three-phase 400V asynchronous motor.

### 4. TECHNICAL DATA AND LIMITATIONS OF USE

	A.D. M/M 1.1	A.D. M/T 1.0	A.D. M/T 2.2	A.D. T/T 3.0	A.D. T/T 5.5
– Max phase current of the motor:	8,5 A	4,7 A	9,3 A	7,5 A	13,3 A
– Line voltage:	230 V	230 V	230 V	400 V	400 V
	single-phase	single-phase	single-phase	three-phase	three-phase
– Line frequency:	50-60 Hz	50-60 Hz	50-60 Hz	50-60 Hz	50-60 Hz
– Electropump voltage:	230 V	230V	230 V	400 V	400 V
	single-phase	three-phase	three-phase	three-phase	three-phase
– Weight of the unit (packing excluded):	4 Kg.	3,8 Kg.	3,8 Kg.	5 Kg.	5Kg.
– Work position:	Any position	Any position	Any position	Facing upward	Facing upward
– Max fluid temperature:	50°C	50°C	50°C	50°C	50°C
– Max working temperature:	60°C	60°C	60°C	60°C	60°C
– Max. pressure:	10 bar	10 bar	10 bar	10 bar	10 bar
– Regulating range:	from 1 to 6 bar	from 1 to 9 bar	from 1 to 9 bar	from 1 to 9 bar	from 1 to 9 bar
– Maximum dimensions (LxHxD):	22x28x18 cm	22x28x18 cm	22x28x18 cm	22x28x18 cm	22x28x18 cm
– Fluid input hydraulic coupling:	1 ¼" male	1 ¼" male	1 ¼" male	1 ¼" male	1 ¼" male
– Fluid output hydraulic coupling:	1 ½"female	1 ½"female	1 ½"female	1 ½"female	1 ½"female
– Degree of protection:	IP 55	IP 55	IP 55	IP 55	IP 55
– Protections:	<ul style="list-style-type: none"> <li>- dry running</li> <li>- overload</li> <li>- excess temperature of the electronics</li> <li>- abnormal feeding voltages (excluding A.D. M/M and A.D. M/T 1.0)</li> <li>- direct short-circuit between the output phases</li> </ul>				

### 5. ELECTRICAL CONNECTIONS OF THE ACTIVE DRIVER TO THE ELECTROPUMP

5.1  Ensure that all the terminals are fully tightened, **paying particular attention to the earth terminal**.

5.2 Check that all the connecting cables are in excellent conditions, with the external sheathing unbroken.

5.3 The motor of the installed electropump must comply with the data in the table in Chapter 4.  
 The user connected to the ACTIVE DRIVER M/M 1.1 must not exceed 8,5 A as phase current.  
 The user connected to the ACTIVE DRIVER M/T 1.0 must not exceed 4,7 A as phase current.  
 The user connected to the ACTIVE DRIVER M/T 2.2 must not exceed 9,3 A as phase current.  
 The user connected to the ACTIVE DRIVER T/T 3.0 must not exceed 7,5 A as phase current.  
 The user connected to the ACTIVE DRIVER T/T 5.5 must not exceed 13,3 A as phase current.

5.4 Connect the electropump to the output cable of the ACTIVE DRIVER, paying particular attention to the earth connection.

 **The incorrect connection of the earth lines to a terminal other than the earth terminal may cause irremediable damage to the whole appliance!**

 **The incorrect connection of the power supply line on output terminals intended for the load may cause irremediable damage to the whole appliance!**

### 6. CONNECTION TO THE POWER SUPPLY LINE

6.1 Connect the ACTIVE DRIVER to the power supply line by means of the power socket.  
 (See values in chapter 4).

6.2 If an extension to the power cable is used the following minimum sections must be respected:

Section of each lead (mm <sup>2</sup> )	Maximum length of the line (metres)
1.5	15
2.5	30
4	60

- 6.3 The ACTIVE DRIVER is already provided with current protections. If a magnetothermal switch is installed in line, it must have a max. capacity of 16A.
- 6.4 The connection of the line to the ACTIVE DRIVER must include the earth line. The total earth resistance must not exceed 100 Ohm.

- 6.5  **To protect the system it is recommended to install a differential switch with correct dimensions, type:**  
**Class A, with adjustable dispersion current, selective, protected against sudden tripping.**  
**The automatic differential switch must be marked with the following two symbols:**



**7. HYDRAULIC CONNECTIONS**

- 7.1 Always install a check valve on the pipe upstream from the ACTIVE DRIVER.  
 For the purposes of operation of the ACTIVE DRIVER it does not matter whether the valve is fitted on the suction or on the delivery of the pump.

- 7.2 The hydraulic connection between the ACTIVE DRIVER and the electropump must not have any derivations. The dimensions of the pipe must be suitable for the electropump installed.

- 7.3  The ACTIVE DRIVER works at constant pressure. This regulation is appreciated if the hydraulic system downstream from the system is of suitable dimensions.  
 Systems made with pipes that have too narrow a section introduce load losses which the appliance cannot compensate; the result is that the pressure is constant on the device but not on the user.

**When electrical and hydraulic installation have been completed, supply power to the system and check the direction of rotation of the electropump. If it is not correct, invert two phases on the motor terminal board.**

**8. CHARACTERISTICS – INTERPRETATIONS – OPERATION**

The ACTIVE DRIVER is an innovative integrated system for controlling electropumps with variable speed, able to keep a constant pressure while the flow rate varies.

The ACTIVE DRIVER is composed of an inverter, a pressure sensor and a flow sensor.







With the exclusion of models M/M 1.1 and M/T 1.0 the ACTIVE DRIVER is provided with 3 inputs and 2 outputs so as to be able to realise certain interface solutions with more complex installations.

**Figure 1** shows the logical function diagram for the connection of the user input terminals.

**Figure 2** shows the logical function diagram for the connection of the alarm output terminals.

**Figure 3** shows the connection diagram for 2 ACTIVE DRIVER units, for the exchange function.

**8.1 CHARACTERISTICS AND INTERPRETATIONS**

Ref.	FUNCTION	
L - N SINGLE-PHASE R - S - T THREE-PHASE		Power supply line connection terminals.
		Line earth system connection terminal.
U - V - W THREE-PHASE R - S SINGLE-PHASE		Three-phase pump 230 V connection terminals
		Pump earth system connection terminal.
<b>J22 - 1</b>	Power supply terminal: + 12V DC – 50Am. (excluding A.D. M/M 1.1 and A.D. M/T 1.0)	
<b>J22 - 2</b>	Connection terminal of input <b>i3</b> for general disabling command. (excluding A.D. M/M 1.1 and A.D. M/T 1.0)	
<b>J22 - 3</b>	Connection terminal of input <b>i2</b> for selecting set point 1. (excluding A.D. M/M 1.1 and A.D. M/T 1.0)	
<b>J22 - 4</b>	0V connection terminal (GND) for joining I3 – I2 to GND. (excluding A.D. M/M 1.1 and A.D. M/T 1.0)	
<b>J22 - 5</b>	Connection terminal of input <b>i1</b> for protection against dry running. (excluding A.D. M/M 1.1 and A.D. M/T 1.0)	

Ref.	FUNCTION
<b>J22 - 6</b>	0V connection terminal (GND) for joining I1 to GND. (excluding A.D. M/M 1.1 and A.D. M/T 1.0)
<b>J22 - 7</b>	Connection terminal: 0V DC (GND). (excluding A.D. M/M 1.1 and A.D. M/T 1.0)
<b>J14 - 01</b>	Remote alarm connection terminal. (excluding A.D. M/M 1.1 and A.D. M/T 1.0) <b>250 Vac – 6 A max resistive load – 3 A max inductive load</b>
<b>J14 - 02</b>	Pump operating connection terminal. (excluding A.D. M/M 1.1 and A.D. M/T 1.0) <b>250 Vac – 6 A max resistive load – 3 A max inductive load</b>
<b>J9</b>	Connection terminals for interconnection and exchange. <b>ATTENTION: For interconnection cables with a length of more than 1 m, it is recommended to use screened cable with the braiding connected to earth (central pin number 2) on both appliances.</b> <b>ATTENTION: Scrupulously respect the connection sequence between the two appliances! (excluding A.D. M/M 1.1)</b>

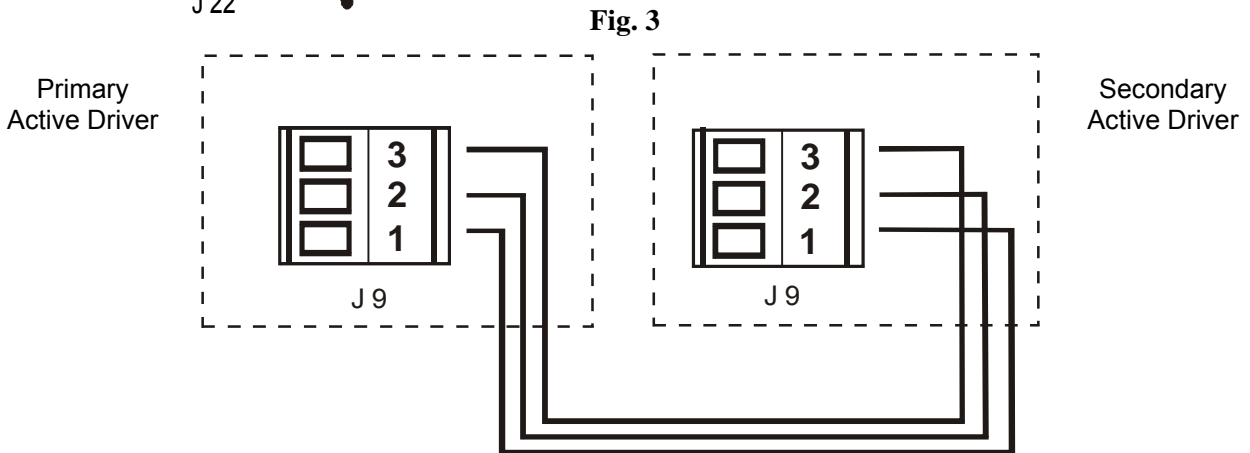
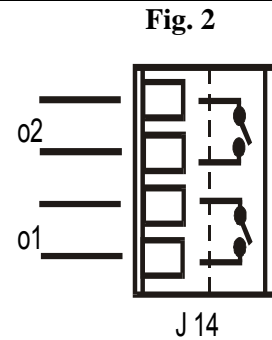
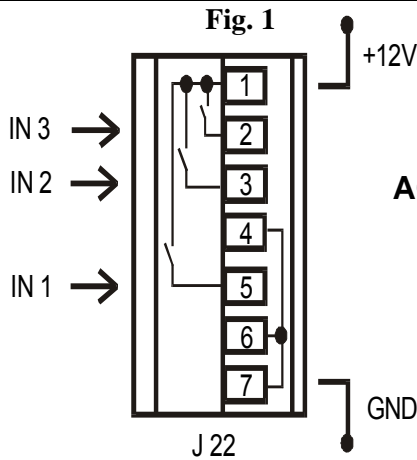

**8.2 OPERATION : KEYBOARD SETTINGS**

<b>MODE</b>	The MODE key allows you to move on to the next items in the individual menus.
<b>SET</b>	The SET key allows you to quit the current menu and return to normal operating status.
<b>+</b>	Press to increase the currently modifiable parameter. Each time it is pressed, the value of the parameter is displayed for at least 6 seconds, after which the identifying symbol appears.
<b>-</b>	Press to decrease the currently modifiable parameter. Each time it is pressed, the value of the parameter is displayed for at least 6 seconds, after which the identifying symbol appears.



When the + key or the – key is pressed, the selected value is modified and saved immediately. Even the accidental shut-down of the machine during this phase does not cause the loss of the newly set parameter. The SET key is used only to return to the display of the machine status. It is not fundamental to press the SET key in order to save the changes made.

**8.3 OPERATION : PARAMETERS FOR THE USER**

Access keys **MODE & SET** for 2 seconds

**8.3.1 SP : Setting the set point pressure ( in bar )**

From normal operating status, hold down the **MODE** and **SET** keys simultaneously until the letters **SP** appear on the display. In these conditions the + and – keys allow you respectively to increase and decrease the desired pressure value.

The regulating range is from 1.0 to 6.0 bar for the A.D. M/M 1.1 and from 1.0 to 9.0 bar for the other models.  
Press **SET** to return to normal operating status.

As well as the working pressure the **ACTIVE DRIVER** allows you to set two other values:

**RP:** expresses in bars the decrease in pressure, with respect to **SP**, that makes the pump restart.

**DP:** expresses in bars the desired decrease in pressure at low flow rates.

The three parameters are related to each other.

**Diagram for regulating pressure according to in flow rate**

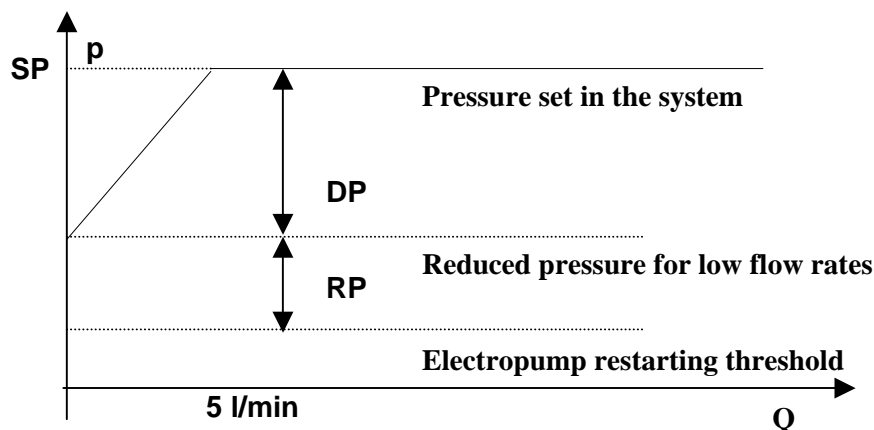

Example:

SP = 4.5 bar

DP = 1.0 bar

RP = 0.7 bar

During normal operation the system will be pressurised at 4.5 bar.

In case of low flow rates (losses) the system will be pressurised at 3.5 bar.

The electropump restarts when the pressure falls below 2.8 bar.

**8.4 OPERATION : PARAMETERS FOR THE INSTALLER**

Access keys **MODE & SET & -** for 5 seconds



**If an error or malfunction occurs during this phase, the display is not changed. Depending on the type of error, the electropump may switch off. However it is still possible to make the desired calibration. To know the type of error that has occurred you must return to the mode in which you see the operating status by pressing the SET key.**

From normal operating status, hold down the **MODE & SET & -** keys simultaneously until the letters “rC” appear on the display. In these conditions the + and – keys allow you respectively to increase and decrease the value of the parameter while the **MODE** key allows you to move on to the next parameter in cyclic mode. Press **SET** to return to normal operating status.

**8.4.1 rC : Setting the rated current of the electropump (excluding A.D. M/M 1.1)**

This parameter must be set the same as the current on the motor data plate (Amps) in the configuration in which it is used (power supply 230V for A.D. M/T - power supply 400V for A.D. T/T).

**8.4.2 rt : Setting the direction of rotation (excluding A.D. M/M 1.1)**

Possible values: 0 and 1

If the direction of rotation of the electropump is not correct, it is possible to invert the direction of rotation by changing this parameter.

If it is not possible to observe the direction of rotation of the motor, proceed as follows:

- Open a user and observe the frequency (parameter Fr with **MODE** key from **GO**) and the current (parameter C1).
- Without changing the amount of water taken, change the parameter rt and observe the frequency Fr and the current C1 again.
- The correct parameter rt is the one which, with the same amount of water taken, requires a lower frequency Fr and current C1.



**8.4.3 od: Setting the operating mode of the ACTIVE DRIVER**

Possible values: 1 and 2

The ACTIVE DRIVER leaves the factory in mode 1 for working without expansion vessels or with small vessels. If there is an expansion vessel near the ACTIVE DRIVER, with a half-inch or larger fitting, you must change to mode 2.

**8.4.4 rP: Setting the fall in pressure for restarting**

Expresses, in bars, the fall in pressure that makes the pump restart.

rP may be set from a minimum of 0.1 to a maximum of 1.5 bar.

rP has a limitation system depending on the combination of the values SP and dP so that there is always a minimum restarting pressure of 0.3 bar.

**8.4.5 Ad : Setting the interconnection address (excluding A.D. M/M 1.1)**

With the ACTIVE DRIVER system it is possible to realise booster sets composed of two elements communicating by means of serial interconnection (see fig.3). In this type of installation it is necessary for the two units to have a different identifying address (Ad).

The admissible values are: “- -”, 1 and 2:

- When “Ad” is “- -” the communication is disabled.
- When “Ad” is “1” it is called Secondary ACTIVE DRIVER (booster).
- When “Ad” is “2” it is called Primary ACTIVE DRIVER (leader).

**Attention:** If two interconnected ACTIVE DRIVER units are set with the same “Ad” value, the communication does not work and there may be malfunctions in regulation.

When the communication does not work (due to incorrect setting of the “Ad” value, for wiring problems, or other reasons), the two ACTIVE DRIVER units will work as though they were two completely independent machines, but they will indicate the impossibility of dialogue by making the display blink when the states “Go” or “Sb” are shown.

When the “Ad” values are correctly set, some regulating parameters are aligned. In particular the secondary ACTIVE DRIVER copies the following values from the primary ACTIVE DRIVER:

- SP : Setting of the set point pressure.
- rP : Setting of the restarting pressure drop.
- Eb : Enabling of the booster pump.
- CM : Method of exchange.
- dP : Setting of the pressure differential at low flow rates.
- P1 : Setting of the input function 2 set point P1.

**Note:** During operation it is possible to change all the parameters of the ACTIVE DRIVER on each of the two machines.

**8.4.6 Eb : Enable booster (pre-set value 2) (excluding A.D. M/M 1.1)**

When two ACTIVE DRIVER units are interconnected with each other, in the case where only one ACTIVE DRIVER is not able to satisfy the user, there is the possibility of activating the two electropumps at the same time.

Eb = 1 : The leader-booster operating mode is disabled, so only one electropump at a time will be active.

If during operation the leader electropump is not able to satisfy the user, the booster electropump will not be switched on.

Eb = 2 : The leader-booster operating mode is enabled, so 2 electropumps can be activated at the same time.

If during operation the leader electropump is not able to satisfy the user, the booster electropump will also be switched on and will work at the maximum frequency, while the leader machine will continue to modulate the rotation frequency according to the user.

**8.5 OPERATION : TECHNICAL ASSISTANCE DISPLAYS AND SETTINGS**

Access keys **MODE & SET & +** for 5 seconds

**8.5.1 tb: Setting the reaction time of the water lack blockage**

The setting of the reaction time of the water lack blockage allows you to select the time (in seconds) taken by the ACTIVE DRIVER system to indicate the lack of water in the electropump. The variation of this parameter may be useful if it is known that there is a delay between the moment in which the electropump is switched on and the moment in which it actually starts delivering.

**8.5.2 GP: Setting the gain of the proportional coefficient of the PI**

**For nearly all systems, the GP parameter set in the factory is the optimum one.** However, if there should be any problems in regulation, this setting may be adjusted. Indicatively it may be said that, for example, the presence of great swings in pressure or of a slow response of the system to variations in pressure may be compensated by high GP values. Instead the occurrence of “vibrations” in pressure (extremely rapid pressure swings around the set point value) may be attributed to too high a GP value.

**8.5.3 GI: Setting the gain of the integral coefficient of the PI**

The integral value must be increased when the system is not very elastic, that is where there is absence of any expansion. On the contrary, in systems with deformable pipes or with delays due to considerable distances between the electropump and the ACTIVE DRIVER, the integral value must be lowered.



**To obtain satisfactory pressure regulations, you generally have to adjust both GP and GI. In fact it is the correct agreement between these two parameters which allows the optimum pressure regulation.**

**8.5.4 FS: Setting the maximum rotation frequency of the electropump**

The ACTIVE DRIVER allows the electropump to be fed for short periods at a frequency higher than the rated one, returning then to 50 Hz without heating the motor.



**When increasing the power supply frequency take care not to exceed the max. current of 9.3 A, otherwise there is a risk of blockage due to current overload in the power stages of F.**

**8.5.5 dP: Setting the pressure differential at low flow rates**

In mode od=01, the setting of the allowed excursion for the pressure set point permits you to select a pressure interval lower than the set point (SP) at which the ACTIVE DRIVER will regulate the pressure in the event of low flow rates.

The advantage of selecting a dP different from zero lies in the redimensioning of the flow rate if there are losses in the system and allows an energy saving so that the electropump can be operated at low speeds when the requested flow rates are low.

To select the possible dP values, the ACTIVE DRIVER is equipped with a limiting system which intervenes when pressure set points lower than 2.0 bar are set. In this case the dP is limited to 0.5. See example on page 29.

**8.5.6 Ft: Setting the low flow rate threshold**

The ACTIVE DRIVER system possesses a flow sensor. Whenever the electropump is switched off a new zero is acquired. The ACTIVE DRIVER switches off the electropump when the flow rate reading is lower than 0 flow (ZF) + the set Ft parameter.

**8.5.7 CM : Method of exchange (pre-set value 1) (excluding A.D. M/M 1.1)**

When two ACTIVE DRIVER units are interconnected to work in exchange it is possible to choose between two different strategies for alternating the switching on of the two electropumps.

**CM = 0 :** The primary ACTIVE DRIVER is always the regulation leader and the secondary ACTIVE DRIVER will be active as a booster (if Eb=2) or as a reserve (if Eb=1). If the secondary machine remains unused for 23 hours, it becomes the leader until it has accumulated one minute of regulation.

If during operation the leader electropump is unable to satisfy the user and the secondary electropump is set as a booster (Eb=2), the latter will work at maximum frequency, while the leader ACTIVE DRIVER will continue to modulate the rotation frequency according to the user.

If the user decreases, the booster machine is switched off, while the leader machine continues regulating.

CM = 1 : The primary and secondary ACTIVE DRIVER alternate in being the regulation leader. The exchange takes place each time the leader ACTIVE DRIVER goes into stand-by mode or after 2 hours of continuous activity.

If during operation the leader electropump is unable to satisfy the user and the secondary electropump is set as a booster (Eb=2), the latter will work at maximum frequency, while the leader ACTIVE DRIVER will continue to modulate the rotation frequency according to the user.

If the user decreases, the leader machine goes into stand-by and becomes the booster (off), while the booster machine becomes the leader (and starts regulating at variable speed).

For each of the two exchange modes, if one of the machine breaks down, the other becomes the leader and carries out regulation at constant pressure up to its maximum available power.

**8.5.8 AE : Enabling the anti-frost function (pre-set value 1)**

Starts rotating the motor-impeller assembly in order to avoid mechanical blockages.

When the anti-frost function is enabled, if the ACTIVE DRIVER measures a temperature that is too low with a risk of frost, it automatically starts running the electropump at a low number of revs (25 Hz).

**8.5.9 Setup of the auxiliary digital inputs IN1; IN2; IN3 with the parameters i1; i2; i3 (excluding A.D. M/M 1.1 and A.D. M/T 1.0)**

The function assigned to each of the digital inputs IN1; IN2; IN3 may be activated or modified by means of the parameters i1; i2; i3.

The setup of the parameters i1,i2,i3 may always assume the values:

0 => function disabled

1 - 3 - 5 => function active on high active input tied to the supply voltage + 12V(see fig. 1)

2 - 4 => function active on low active input tied to GND 0V (see fig. 1)

**ATTENTION: The values 3 – 4 – 5 ONLY FOR INPUT IN3 AND PARAMETER i3.**

Table summarising the configuration of the digital inputs IN1, IN2, IN3							
	Parameter	Value					
		0	1	2	3	4	5
With the intervention of the command the system goes into block and alarm status with indication F1 on the display.	i1	Each function is disabled F1 never appears.	Protection against dry running With input IN1 closed.	Protection against dry running With input IN1 open.	--	--	--
With the intervention of the command the active set point = P1.	i2	Each function is disabled F2 never appears.	Active set point =P1 With input IN2 closed.	Active set point =P1 With input IN2 open.	--	--	--
With the intervention of the command the ACTIVE DRIVER is deactivated with indication F3 on the display.	i3	Each function is disabled (default) F3 never appears.	ACTIVE DRIVER disabled With input IN3 closed.	ACTIVE DRIVER disabled With input IN3 open.	ACTIVE DRIVER disabled. With input IN3 closed + eliminate blockages and reset.	ACTIVE DRIVER disabled. With input IN3 open + eliminate blockages and reset.	Eliminate blockages and reset.

**8.5.10 Setting the set point P1 function of input 2 (excluding A.D. M/M 1.1 and A.D. M/T 1.0)**

When the parameter i2 is set at a value other than zero, with the input 2 it is possible to select one of the two settable set points. The first is SP. The second is P1. The regulating range is from 1.0 to 9.0 bar.

**8.5.11 O1: Setting output 1 function ( “active alarm” ) (excluding A.D. M/M 1.1 and A.D. M/T 1.0)**  
**O2: Setting output 2 function ( “pump operating” ) (excluding A.D. M/M 1.1 and A.D. M/T 1.0)**

<b>Assigning the parameters that associate functions with the digital outputs OUT1; OUT2</b>				
Assigning the parameters	Value			
	0	1	2	3
o1	Each function is disabled. Contact always open	Each function is disabled. Contact always closed	In case of blocking errors the contact closes (default)	In case of blocking errors the contact opens
o2	Each function is disabled. Contact always open	Each function is disabled. Contact always closed	When the electropump is operating the contact closes (default)	When the electropump is operating the contact opens

**9. DISPLAYS ( see table no. 14 page 36 )**

**9.1 DISPLAYS OF THE MAIN VALUES**

**Access key MODE**

From normal operating status, pressing the **MODE** key displays the following values:

**Fr: Display of the current rotation frequency (in Hz).**

**UP: Display of pressure (in bar).**

**C1: Display of the phase current of the electropump (in A).**  
 (excluding A.D. M/M 1.1 and A.D. M/T 1.0)

**UE: Display of the version of the software with which the appliance is equipped.**

**9.2 MONITOR DISPLAYS**

**Access keys SET & - for 2 seconds**

From normal operating status, pressing the key **SET & -** enters the **MONITOR** function where the following values are displayed:

( **NB: to scroll through the values press the MODE key** )

**UF: Display of the flow**

Display of the instantaneous flow.

Parameter to be used only as a reference in programming.

**ZF: Display of zero flow**

Display of the reading of the flow sensor on which zero was acquired (with electropump switched off). During normal operation the **ACTIVE DRIVER** will use this parameter to switch off the electropump.

**FM: Display of the maximum rotation frequency (in Hz)**

**tE: Display of the temperature of the power stages (in °C)**

**GS: Display of running status**

SP = pump operating to maintain pressure “SP”.

P1 = pump operating to maintain pressure “P1” (input 2 active).

AG = pump operating for “anti-frost”.

**FF: Display of fault history (+ & - to scroll through the alarms)**

There is a queue of 16 positions for containing the last 16 faults which have occurred during system operation. By pressing the – key you can go back in history and stop at the oldest fault present, whereas by pressing the + key you can go forward in history and stop at the most recent fault present.

The decimal point identifies the last fault to have occurred in chronological order.

The history contains at the most 16 positions. Each new fault is inserted in the most recent position (decimal point). For each fault after the sixteenth, the oldest one in the queue is erased. The history of the faults is never erased but only updated as new faults occur. Manual reset and switching off of the appliance do not erase the history of faults.

**10. ACCESS TO MANUAL MODE OF THE MACHINE**

**Access keys SET & + & - for 5 seconds**

**During this phase all the controls and protection systems of the ACTIVE DRIVER are disabled!**



Use of the keys.	
Keys pressed	Action
“SET” & “+” & “-“	Press them together for a few moments until the display shows MA
+	Increases the frequency and rotation of the electropump
-	Decreases the frequency and rotation of the electropump
MODE	Moves on to the next item in the following menu FP = <b>Setting</b> of the test frequency in manual mode (Hz) ≤ at the set FS value UP = Display of pressure (bar) C1 = Display of the electropump phase current (A) rt = <b>Setting</b> of the direction of rotation UF = Display of flow ZF = Display of zero flow
MODE & -	The electropump runs at the set frequency as long as the keys are held down
MODE & - & + (for 2 seconds)	The electropump remains operating at the set frequency The electropump may be switched off by pressing MODE & -
SET	Press to leave manual mode

When the system is in manual mode the whole display blinks.

**11. GENERAL SYSTEM RESET**

Access keys **MODE & SET & + & -**

To restart the appliance without disconnecting the power supply press the 4 keys simultaneously.

**MODE & SET & + & -**

**12. RESTORING THE FACTORY SETTINGS**

Access keys **SET & + for 2 seconds when switching on**

The factory settings are indicated in table no. 14 on page 36.

To reset the factory values:

Switch off the appliance, press and hold down the SET and + keys while switching on the appliance again, release the two keys only when the letters EE appear. In this case the ACTIVE DRIVER restores the factory settings.

When it has finished setting all the parameters the ACTIVE DRIVER returns to normal operation.



**In this phase, in the models in which RC is active, the motor current is set at 0 as factory default, so when you try to start the electropump it will immediately give the error EC. Go to the installer’s display and settings menu (keys MODE & SET & - for 5 seconds ) and set the correct motor data plate current (parameter rC as in paragraph 8.4.1.)**

**13. ERROR AND STATUS CONDITIONS**

**The ACTIVE DRIVER is equipped with a protection system against malfunctions. If any malfunctions occur, this is indicated on the display and, depending on the type of error, the electropump may switch off.**

In cases of blockage due to water lack (bL), blockage due to current overload in the electropump (oC), blockage due to current overload in the output stages (oF), blockage due to direct short circuit between the phases of the output terminal (SC) and of low line (LL) indication, you may try to exit the error conditions by pressing the “+” and “-” keys simultaneously. If the error condition remains, you must take steps to eliminate the cause of the malfunction.

Error conditions	
Error and status conditions	
Display indication	Description
bL	Blockage due to water lack
LP	Blockage due to low supply voltage
HP	Blockage due to high rectified voltage
LL	Low line voltage indication
ot	Blockage due to overheating of the power stages
oC	Blockage due to current overload in the electropump motor
oF	Blockage due to current overload in the output stages
SC	Blockage due to direct short circuit between the phases of the output terminal
EC	Blockage due to incorrect setting of the rated current
E0...E7	Blockage due to internal error 0...7
F1	Blockage due to input 1 status
F3	Blockage due to input 3 status

**13.1 “bL” Blockage due to water lack**

In conditions of zero flow the system switches off the pump. If, by mistake, a pressure set-point is set which is higher than the maximum pressure that the electropump can supply, the system indicates “blockage due to water lack” (bL) even if there is really no lack of water. Then you must lower the switch-off pressure to a reasonable value that normally does not exceed 2/3 of the head of the installed electropump.

**13.2 “LP” Blockage due to low supply voltage (excluding A.D. M/M 1.1 and A.D. M/T 1.0)**

When the line voltage at the supply terminal falls below 180V, the ACTIVE DRIVER goes into block status due to low line voltage. This is reset only automatically when the voltage at the terminal rises above 200V.

If the dimensions of the wiring are not suitably large, this block may occur when the electropump is started even if higher voltages are measured with the machine in stand-by mode.

**13.3 “LL” Blockage due to low supply line (excluding A.D. M/M 1.1 and A.D. M/T 1.0)**

This indication is given when more than 5 falls in the supply voltage (LP) are recorded in the space of an hour. However the appliance continues operating regularly. Repeated switch-offs of the appliance do not cause the appearance of the “LL” signal.

If the signal “Low line voltage” (LL) is given, the system does not block and the normal indications of operating status or error continue to alternate on the display.

The ACTIVE DRIVER is equipped with an electronic protection for current overloads in the electropump motors.

**13.4 “SC” Blockage due to direct short circuit between the phases of the output terminal**

The ACTIVE DRIVER is equipped with protection against the direct short circuit which may occur between the phases U, V, W of the “PUMP” output terminal. When this block status is indicated, you are advised to eliminate the short circuit and to check the wiring carefully to ensure it is unbroken and the installation in general. Once these checks have been made you can try to reset operation by simultaneously pressing the “+” and “-” keys; **anyway, this will have no effect until 10 seconds have passed from the moment in which the short circuit occurred.**

Whenever a short circuit occurs, an event counter is increased and saved in the permanent memory (EEPROM).

**AFTER THE HUNDREDTH SHORT CIRCUIT THE MACHINE BLOCKS PERMANENTLY AND IT WILL NO LONGER BE POSSIBLE TO UNBLOCK IT!**

**13.5 MANUAL RESET of error condition**

In error status the operator can reset the error by forcing a new attempt, pressing the “+” and “-” keys simultaneously.

**13.6 Self-reset of error conditions**

For some malfunctions and block conditions, the system makes attempts at automatic reset of the electropump.

The following table shows the sequences of the operations performed by the ACTIVE DRIVER for the different types of blockage.

Automatic resets of error conditions		
Display indication	Description	Sequence of automatic reset
bL	Blockage due to water lack	- An attempt every 10 minutes for a total of 6 attempts - An attempt every 1 hour for a total of 24 attempts - An attempt every 24 hours for a total of 30 attempts
LP	Blockage due to low supply voltage	- Reset when voltage returns to a value in the range 220V - 20% + 10%
HP	Blockage due to high voltage	- Reset when the internal voltage returns in acceptable conditions
Ot	Blockage due to overheating of the power stages	- Reset when the temperature of the power stages falls below 70°C again
OC	Blockage due to current overload	- An attempt every 10 minutes for a total of 6 attempts
oF	Blockage due to current overload in the output stages	- An attempt every 10 minutes for a total of 6 attempts

14. INDICATIONS ON THE DISPLAY

Identifying s.	Description	Factory parameters				
		A.D. M/M 1.1	A.D. M/T 1.0	A.D. M/T 2.2	A.D. T/T 3.0	A.D. T/T 5.5
Go	Electropump operating					
Sb	Electropump waiting					
<b>User displays and settings (keys MODE &amp; SET 2 seconds )</b>						
SP	Setting the set-point pressure ( in bar ). Default: 3 bar	3.0 bar	3.0 bar	3.0 bar	3.0 bar	3.0 bar
<b>Installer displays and settings (keys MODE &amp; SET &amp; - 5 seconds )</b>						
rC	Setting the rated current of the electropump		0.0 A	0.0 A	0.0 A	0.0 A
rt	Setting the direction of rotation		00	00	00	00
od	Setting the operating mode	01	01	01	01	01
rP	Setting the pressure drop for restarting	0.3 bar	0.3 bar	0.3 bar	0.3 bar	0.3 bar
Ad	Setting the interconnection address		"_ _"	"_ _"	"_ _"	"_ _"
Eb	Enabling the booster		02	02	02	02
<b>Technical assistance displays and settings (keys MODE &amp; SET &amp; + 5 seconds )</b>						
tb	Setting the reaction time of the water lack blockage	10 s	10 s	10 s	10 s	10 s
GP	Setting the gain of the proportional coefficient of the PI	1.0	1.0	1.0	1.0	1.0
GI	Setting the gain of the integral coefficient of the PI	1.0	1.0	1.0	1.0	1.0
FS	Setting the maximum rotation frequency of the electropump	50	50	50	50	50
dP	Setting the pressure differential at low flow rates	0.0 bar	0.0 bar	0.0 bar	0.0 bar	0.0 bar
Ft	Setting the low flow rate threshold	15	15	15	15	15
CM	Exchange method		01	01	01	01
AE	Setting the enabling of anti-frost function	01	01	01	01	01
i 1	Setting the function of input 1 (float)			01	01	01
i 2	Setting the function of input 2 (set point selection)			01	01	01
i 3	Setting the function of input 3 (enable )			01	01	01
PI	Set point 1: input 2 function			2.5 bar	2.5 bar	2.5 bar
O 1	Setting the function of output 1 (default value: 2; function: ON alarm )			02	02	02
O 2	Setting the function of output 2 (default value: 2; function: ON operating )			02	02	02
<b>Displays of the main values (MODE key)</b>						
Fr	Display of the current rotation frequency (in Hz)					
UP	Display of pressure (in bar)					
C1	Display of the phase current of the electropump (in A)					
UE	Display of the version of the software with which the appliance is equipped					
<b>DISPLAY (keys SET &amp; "-" for 2 seconds )</b>						
UF	Display of the flow					
ZF	Display of zero flow					
FM	Display of the maximum rotation frequency (in Hz)					
tE	Display of the temperature of the power stages (in °C)					
GS	Display of running status					
FF	Display of fault history ( "+" e "-" to scroll )					
<b>Access to manual mode (keys SET &amp; + &amp; - 5 seconds ) (d)</b>						
MA	Operation in manual mode					
<b>System reset (keys MODE &amp; SET &amp; + &amp; - )</b>						
"ZF"	General reset ( ZF appears when leaving reset and restarting )					
<b>Restoring the factory settings (keys SET &amp; + for 2 seconds when switching on)</b>						
EE	Saving and reading the factory settings on the EEPROM					
<b>Error and status conditions</b>						
bL	Blockage due to water lack					
LP	Blockage due to low supply voltage					
HP	Blockage due to high supply voltage					
LL	Low line voltage					
ot	Blockage due to overheating of the power stages					
oC	Blockage due to current overload in the electropump motor					
oF	Blockage due to current overload in the output stages					
SC	Blockage due to direct short circuit between the phases of the output terminal					
EC	Blockage due to incorrect setting of the rated current					
E0...E7	Internal error 0...7					
F1	Blockage due to input 1 status					
F3	Blockage due to input 3 status					

---

---



---

---

---

---

---

**DAB PUMPS S.p.A.**

Via M. Polo, 14-35035 Mestrino (PD) - Italy  
Tél. +39 049 90 48811 - Fax + 39 049 9048847  
<http://www.dabpumps.com>  
Ventes Italie zone Nord :  
tél. 049 9048873 Fax 049 9048888  
Ventes Italie zone Centre Sud :  
tel. 049 9048874 Fax 049 9048888  
Gestion Dépôts :  
tél. 049 9048875 Fax 049 9048888  
Service après-vente :  
tél. 049 9048911 Fax 049 9048920

**DAB PUMPS Ltd**

Unit 4, Stortford Hall Industrial Park,  
Dunmow Road, Bishops Stortford,  
Hertfordshire,  
CM23 5GZ  
Tel. 01279 652776

**DAB PUMPEN DEUTSCHLAND  
GmbH**

Tackweg 11  
D - 47918 Tonisvorst  
Tel. 0049 2151 82136 0  
Fax 0049 2151 82136 36

**DAB PUMPS B.V.**

Albert Einsteinweg, 4  
NL - 5151 DRUNEN  
Tel. 0031 4163 80408  
Fax 0031 4163 80181

**DAB POMPES S.A.**

Brusselstraat, 150  
B-1702 Groot-Bijgaarden  
Tel. 0032 2 4668353  
Fax 0032 2 4669218

03/06 cod.0013.550.91